

**LINDNER**



**URRACO 95  
MOBILE SHREDDING**

**THE MEASURE  
OF ALL THINGS.**

ONLY LINDNER CLIENTS CAN TRULY SAY:

# LEAVES EVERYTHING IN THE DUST.

**TAKES MOBILE SHREDDING TO THE EXTREME: MAXIMUM OUTPUT, FULL MOBILITY.**

Thanks to its extremely powerful engine, long shaft length and aggressive intake, the twin-shaft Urraco 95 DK shredder makes short work of every material. Extremely efficient and reliable with low wear and tear, this machine is maintenance-friendly and has a low rate of energy consumption per tonne of shredded material.



## 1. ROBUST TWIN-ROTOR CUTTING SYSTEM

**Incredibly productive** thanks to aggressive intake and synchronous running of the shafts.  
**Maximum resistance** with our welded crushers, rippers, scrapers and breaker bars.  
**Adapts perfectly to the material** thanks to shaft pairs available in different designs.



## 2. POWERFUL DIESEL ENGINE

**Efficient shredding** with our 770 hp diesel engine from Scania.  
**Complies with all exhaust gas regulations** thanks to our state-of-the-art SCR system.  
**Particularly long service life** ensured by an ideal interaction between the engine and the hydraulics.

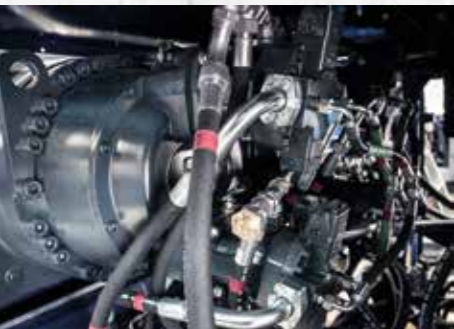

## 3. PROVEN MOBILE HYDRAULICS

**High output** thanks to the self-regulating hydrostatic double drive.  
**Effective shredding** with a torque of up to 480,000 Nm and robust planetary gears.  
**Safe operation** owing to the lightning speed automatic detection of non-shreddables.

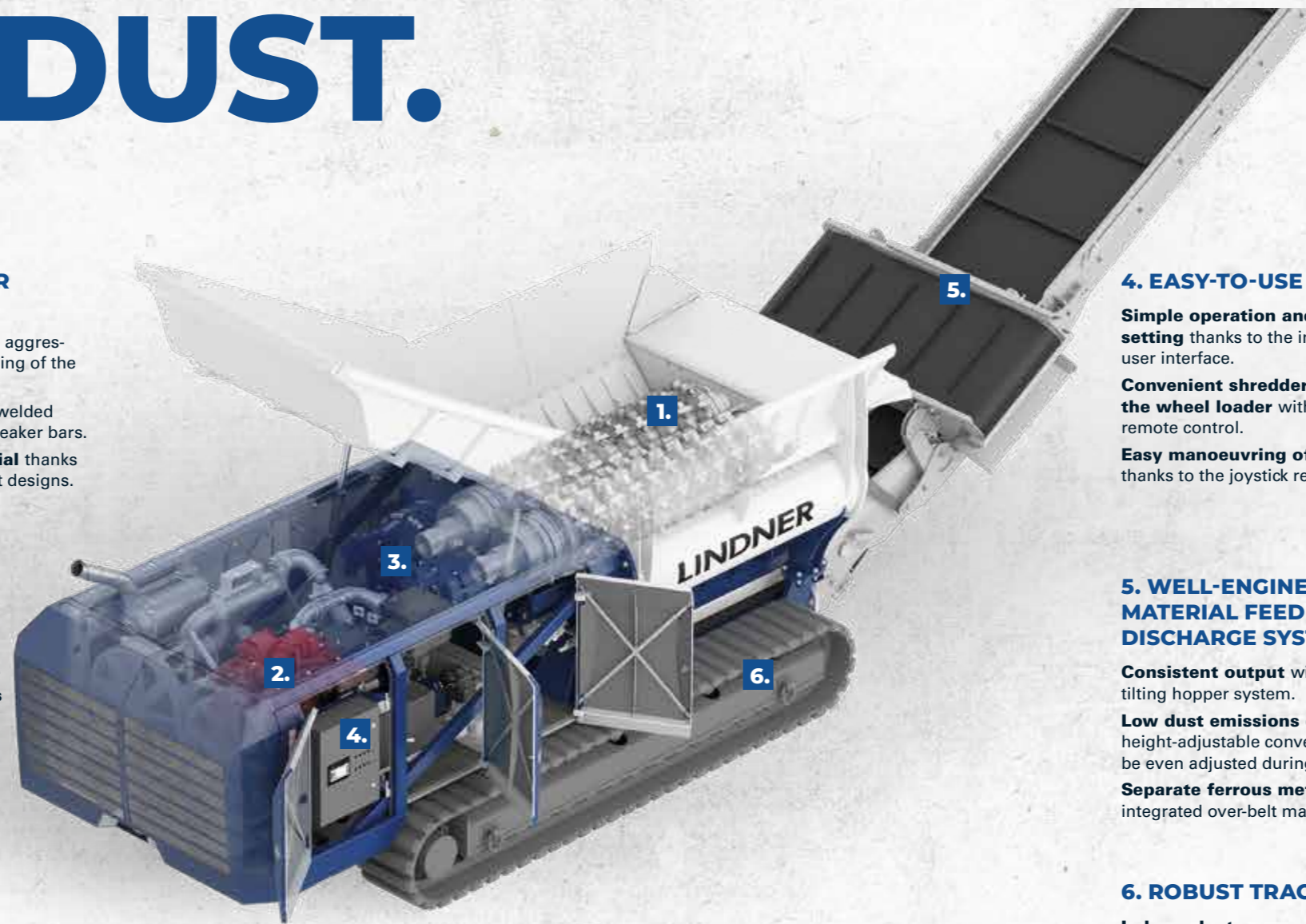

## 4. EASY-TO-USE CONTROL

**Simple operation and parameter-setting** thanks to the intuitive touchscreen user interface.  
**Convenient shredder operation from the wheel loader** with our customisable remote control.  
**Easy manoeuvring of the shredder** thanks to the joystick remote control.



## 5. WELL-ENGINEERED MATERIAL FEED AND DISCHARGE SYSTEMS

**Consistent output** with our smart double tilting hopper system.  
**Low dust emissions** due to hydraulic height-adjustable conveyor belt, which can be even adjusted during operation.  
**Separate ferrous metals** with optional integrated over-belt magnet.



## 6. ROBUST TRACKED CHASSIS

**Independent manoeuvring of the machine** thanks to hydraulic crawler tracks.  
**Secure hold and anchoring** for maximum stability in operation.  
**Optional rubber pads** are available for gentle operation on tarmacked areas.



# TECHNICAL DATA

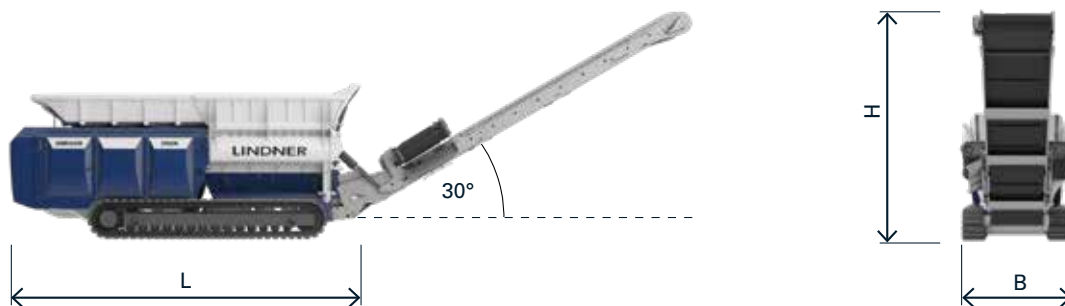

## URRACO 95DK

Drive Power Diesel	hp	770
Exhaust Gas Standard		- / USTier 4f
Type		Track
Shaft Length	mm	2 x 2500
Max. Torque	Nm	480.000
Total Weight	t	42
Measure (LxBxH)	mm	9200 x 3000 x 3200
Discharge Height (30°)	mm	5500

\*The stated values refer to standard machine versions with a standard hopper and raised feet. The right to make technical changes is reserved.

### SHAFTS FINE

*The specialist for the fine grain*



Waste wood A1 – A2  
Biomass  
Green cuttings  
Rootstocks  
Paper rolls  
Tarpaper  
Plastics  
etc.

**Output: 100 – 200 mm**

### SHAFTS ROUGH

*The specialist for the rough stuff*



Waste wood A1 – A4  
Household refuse  
Bulky commercial  
Waste  
Rootstocks  
Railway sleepers  
Metals  
Light iron scrap  
Light aluminium scrap  
Electronic scrap  
etc.

**Output: 300 – 500 mm**



Magnetic separator of  
ferrous material



Water sprinkling system



engine compartment  
extinguishing system



Extended wear protection

## Lindner-Recyclingtech GmbH

Villacher Straße 48 | 9800 Spittal/Drau | Austria

t.: +43 4762 2742 | f.: +43 4762 2742-9032 | office@l-rt.com

[www.l-rt.com](http://www.l-rt.com)